



Defender™ 5000 Series

General Purpose Indicator, Bases and Bench Scales



Smart Functionality, Durability, Ohaus Quality & Value

The OHAUS Defender™ 5000 Series is a feature-rich line of indicators, bases and bench scales, that is ideal for shipping and receiving, production, packing and general commercial and industrial weighing applications. The Defender 5000 for general purpose applications features rugged stainless steel pans and painted steel frames and columns. Its durable ABS plastic indicator is a powerful weighing machine; by enabling its various modes, you have the flexibility to customize the scale for a wider variety of specific applications at no additional cost or complexity. With rugged construction, comprehensive yet intuitive software operations, multiple connectivity options, optional NiMH battery operation and flexible mounting capabilities, the Defender 5000 is your dependable one-product solution for an expandable range of weighing operations.

Standard Features Include:

- Five popular capacities: 15kg, 30kg, 60kg, 150kg and 300kg, 6 platform sizes, square and rectangular, from 305 x 305 mm to 610 x 610 mm
- Stainless steel pans with painted carbon steel frames and columns, OIML R60 approved IP67 aluminum load cells
- Scale displayed resolutions 1:12,000 - 15,000 (with temporary high resolution display), approvable to 1:3000e
- ABS plastic indicator with displayed resolutions up to 1:30000, and drives up to 8 x 350 ohm load cells
- Reversible rear housing for convenient orientation of cables, and flexible mounting capabilities with angle-adjustable bracket
- High contrast single-line backlit LCD display with 25mm tall digits, 3-color checkweigh LED and setpoint beeper
- Four function keys, raised, tactile membrane switches with menu navigation text and key-press beeper
- Multiple weighing units: kg, g, lb, oz, lb:oz, t, and custom unit
- Multiple user-activated modes: counting (with auto-optimization), checkweighing, percent weighing, dynamic-animal weighing and display hold
- AC line cord with universal switching power supply, 6-C dry cell battery operation or optional rechargeable NiMH battery

Defender™ 5000 General Purpose Indicator

Indicator Specifications

Model	T51P
Construction	ABS plastic with internal reinforcing ribs, reversible rear housing, painted steel wall mount bracket with adjustment knobs
Full Scale Capacity Range	1 to 999,950 kg/lb
Max Displayed Resolution	1:30,000d
Maximum Approved Resolution	1:10,000e / Dual range 1:3000e
Maximum Counting Resolution	1:300,000d
Min Average Piece Weight (APW)	0.1d
Weighing Units	kg, lb, g, oz, lb:oz, tonnes, custom
Weight Display	6-digit, 7-segment LCD, 25mm High digits, with high-contrast white LED backlight
Checkweigh Indication	3-color LED with configurable beeper signal
Keyboard	4 function membrane switches, with positive feedback
Extra Functions/Modes	Display Hold, Dynamic Weighing, Counting, Checkweighing, Percent Weighing
Other Software Features	Zero calibration, Calibration test, Geographical gravity adjustment, Auto-tare, Auto-tare on-accept, GMP Time-Date, Key function lock, temporary display of higher resolution
Load Cell Excitation Voltage	5V DC
Load Cell Input Sensitivity	up to 3 mV/V
Load Cell Drive	up to 8 x 350 ohm load cells
Stabilization Time	within 2 seconds
Zeroing Range	2% or 100% of capacity
Span Calibration	1 kg/lb to 100% of capacity
Interface	Built-in RS232 and external input / Optional RS422/485 / optional AC relay / Optional DC relay / optional second RS232
Operating Temperature Range	-10°C to 40°C
Relative Humidity Range	Maximum 80% up to 31°C, decreasing linearly to 50% at 40°C
Power	100-240 VAC / 50-60 Hz, internal universal power supply, line cord, 6 C-type dry cell batteries (80-hr. typical operation), optional internal rechargeable NiMH battery (30-hr. typical operation)
Enclosure Dimensions	260W x 71D x 168H mm
Overall Dimensions (inc. bracket)	316W x 71D x 224H mm
Net / Shipping Weight	1.5 kg / 2.3 kg
Shipping Dimensions	330W x 240D x 180H mm

Outline Dimensions

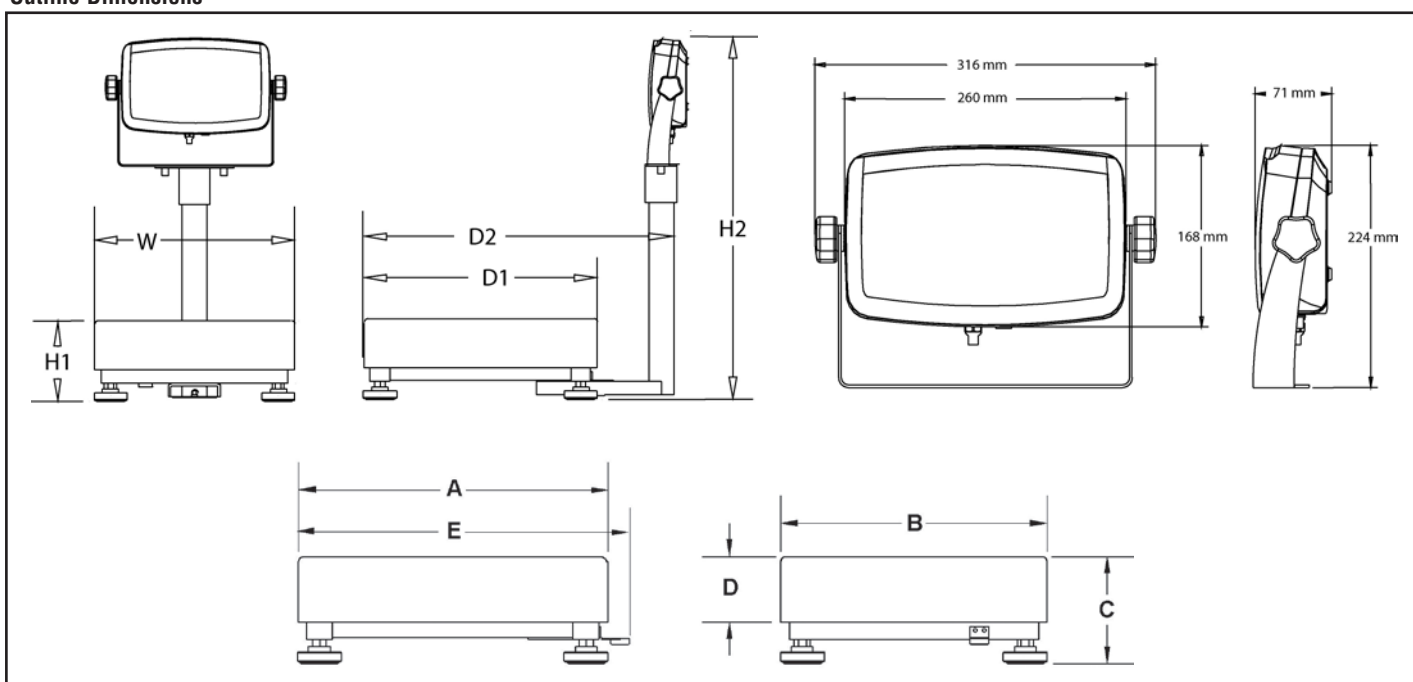

Standard Features

Simple Plug-In Battery Installation



Use six C- alkaline batteries or the optional NiMH battery

High-Visibility LCD Display

with bright white LED backlight. Fast display stable weight within 2 seconds

Reversible Rear Housing

Cables can exit above (table or front scale mounting) or below (wall or bench scale mounting) for convenient mounting. Front scale mounting with available accessory. Internal structural ribs provide strength and minimize flexing.



3-Color LED Checkweigh Indication

with configurable beeper alert

Included Table/Wall Mount Bracket

With large ergonomic adjustable knobs to maximize viewing angles. A ratchet-type angle adjustment with a metal inserts ensures that viewing angles are set securely, and lasts long even with frequent adjustments



One-Key, Multiple Mode Selection

Counting, Dynamic Weighing, Display Hold, Percent Weighing and Checkweighing

Universal Switching Power Supply

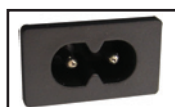

100-240 VAC with AC line cord; no need for AC adapter!

Stay Connected

Built in RS232 bi-directional, built-in external input, optional RS422/485, optional second RS232 and optional AC or DC relay

Painted Steel Columns

Available in both short and tall lengths with compatible base mounting, they offer flexible mounting possibilities.

Plug-in Load Cell Connector

Allows for simple connection to Defender bases or directly to terminal block. Available sealing collar for Type-approval applications



Fully Adjustable Feet

Four rugged, adjustable feet help prevent slippage on wet or uneven surfaces

Durable Base Frame Construction

Stainless steel pans and form-and-weld frames provide maximum durability, rigidity and structural integrity. Load-unload cycle tested to ensure accurate long-term performance.



Options and Accessories

Interface Options

	OHAUS Number
AC Relay Kit, T51P/T51XW.....	80500720
DC Relay Kit, T51P/T51XW.....	80500727
RS422/485 Interface Kit, T51P/T51XW.....	80500731
RS232 Interface Kit, T51P/T51XW.....	80500733
Foot Switch.....	71173378

Power Options

Rechargeable Battery Kit, T51P/T51XW.....	80500729
---	----------

Approval Options

Load cell cable sealing collar, T51P.....	80500737
---	----------

Mounting Accessories

Wall Mount Kit, T51P.....	72200227
Wall Mount Kit, T51XW.....	80500735
Base Mount Kit, T51P.....	80500722
Column Mount Kit, 35cm, painted, T51.....	80500723
Column Mount Kit, 68cm, painted, T51.....	80500724

Mounting Accessories (continued)

	OHAUS Number
Column Mount Kit, 35cm, stainless steel, T51.....	80500725
Column Mount Kit, 68cm, stainless steel, T51.....	80500726

Compatible with all existing columns for Champs-CD/CW11/CD3X/CKW

Other Accessories

Load Cell Cable Adapter Kit.....	80500736
RS232 Cable, T31-51P to SF42 Printer.....	80500571
RS232 Cable, T31-51P to PC 25-pin.....	80500524
RS232 Cable, T31-51P to PC 9-pin.....	80500525
RS232 Cable, T31-51XW/CW11 to SF42 Printer.....	80500574
RS232 Cable, T31-51XW/CW11 to PC 25-pin.....	80500553
RS232 Cable, T31-51XW/CW11 to PC 9-pin.....	80500552
Compact Impact Printer, 42 Column.....	SF42
Paper for SF42 printer (5 pack).....	12101511
Ribbon for SF42 printer.....	12101512

Defender™ 5000 *General Purpose Bench Scales*

Base Specifications

Base Models	D15QR	D15HR	D30QR	D30HR	D60HR	D60QL	D60HL	D150QL	D150HX	D300QX	D300HX
Capacity (Max)	15kg		30kg		60kg		150kg		300kg		
Construction	304 stainless steel pan, painted carbon steel frame, non-slip rubber leveling feet										
Leveling Components	Externally visible level bubble and adjustable leveling feet										
Operating Temperature	-10°C to 40°C										
Safe Overload Capacity	150% of rated capacity										
Load Cell Type	IP67, aluminum, single point / C3										
Load Cell Cable	2m L x 6-wire										
Load Cell Rated Output	2 mV/V ± 10%										
Load Cell Excitation Voltage	Maximum 20V (AC/DC) / Recommended 5~15V (AC/DC)										
Load Cell Input / Output Resistance	410 ± 10 ohms / 350 ± 4 ohms										
Base Dimension (AxBxCxDxE) (mm)	Q Series:	305 x 305 x 95 x 52 x 335				457 x 457 x 115 x 70 x 487		610 x 610 x 137 x 90 x 640			
	H Series:	355 x 305 x 95 x 50 x 380				500 x 400 x 105 x 60 x 530		550 x 420 x 125 x 70 x 580			
Shipping Dimensions (mm)	Q Series:	490L x 410W x 440H				810L x 600W x 240H		1000L x 760W x 250H			
	H Series:	490L x 410W x 440H				740L x 690W x 230H		750L x 710W x 230H			
Net / Shipping Weight	Q Series:	12.2 kg / 14.2 kg				27.2 kg / 29 kg		35 kg / 41 kg			
	H Series:	9 kg / 11 kg				19 kg / 22 kg		24.5 kg / 27 kg			

Scale Specifications

Scale Models	D51P15QR1	D51P15HR1	D51P30QR1	D51P60QR1	D51P60HR1	D51P60QL2	D51P60HL2	D51P150QL2	D51P150HX2	D51P300QX2	D51P300HX2
Base Model	D15QR	D15HR	D30QR	D30HR	D60HR	D60QL	D60HL	D150QL	D150HX	D300QX	D300HX
Indicator Model	T51P										
Capacity x Max Readability (d)	15kg x 1g / 1:15000d		30kg x 2g / 1:15000d		60kg x 5g / 1:12000d		150kg x 10g / 1:15000d		300kg x 20g / 1:15000d		
Capacity x Approved Readability (e)	15kg x 5g / 1:3000e		30kg x 10g / 1:3000e		60kg x 20g / 1:3000e		150kg x 50g / 1:3000e		300kg x 100g / 1:3000e		
Column	350 mm fixed height, hollow tubular, painted steel					680 mm fixed height, hollow tubular, painted steel					
Scale Dimensions (WxH1xH2xD1xD2)	Q Series:	305 x 95 x 600 x 305 x 425 mm				457 x 115 x 940 x 457 x 577		610 x 137 x 940 x 610 x 730			
	H Series:	305 x 95 x 600 x 355 x 475 mm				400 x 105 x 940 x 500 x 620		420 x 125 x 940 x 550 x 670			
Shipping Dimensions	Q Series:	490L x 410W x 440H mm				810L x 600W x 240H mm		1000L x 760W x 250H mm			
	H Series:	490L x 410W x 440H mm				740L x 690W x 230H mm		750L x 710W x 230H mm			
Net / Shipping Weight	Q Series:	11.7kg / 14.1kg				24.8kg / 27.7kg		41.3kg / 44.7kg			
	H Series:	11.9kg / 14.2kg				23kg / 25.7kg		28.3kg / 30.7kg			

Compliance

- **Safety and EMC:** EN60950, EN61326, FCC, CE, UL_{us}
Compliant to Directive 2002/96/EC on waste electrical and electronic equipment (WEEE)
- **Type Approval/Legal-for-Trade:**
 - T51xx Series Indicator: EC Type approval and Test Certificate: TC7132 / T5980
 - Load Cells: OIML R60/2000-NL1-03.10 / TC5382; OIML R60/2000-NL1-03.14 / TC5367
- **Quality:** Ohaus quality management system registered to ISO 9001:2008



Proudly Sold & Serviced By:
Able Scale Co Pty Ltd
 Ph: 1300 731 360

21 Green St Thomastown VIC. 3074

find us on the web: www.ablescale.com.au

www.ohaus.com

* ISO 9001:2008
 Registered Quality Management System

80774295_A © Copyright Ohaus Corporation

